

ALL TIME

L - POSITIONER

Loading capacity:

ranging from 750kg to 5000 kg.

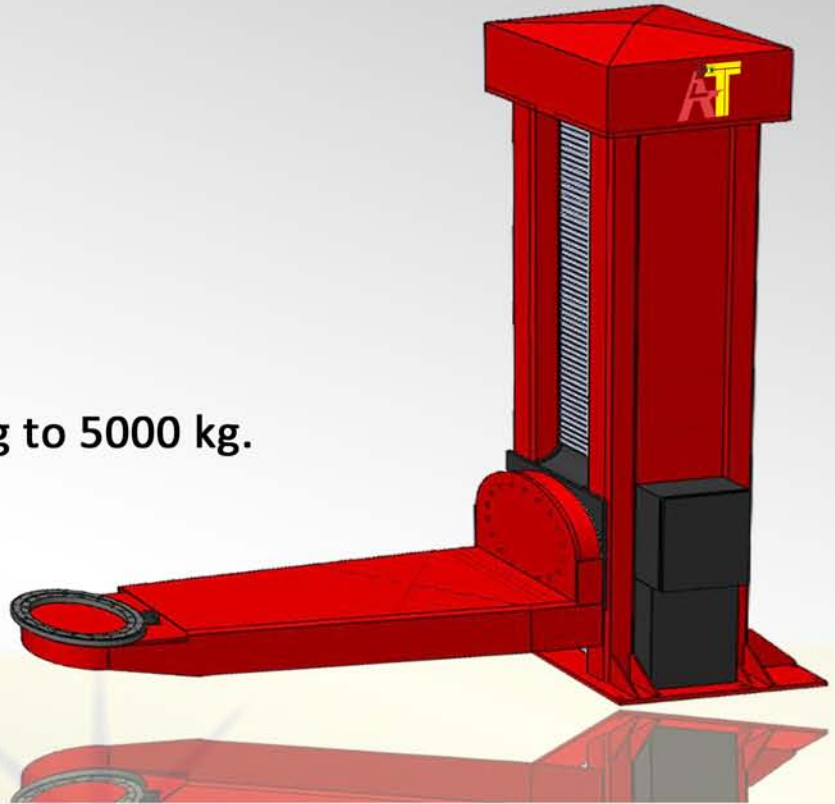

ALL TIME offers high quality L Positioner. It is designed to handle demanding tasks with heavy work-piece with even the most complex product geometry. With ALL TIME L Positioner, work-pieces are easily set up in a wide variety of attitudes.

ALL TIME L - Positioner is the right equipment for heavy work-piece with demanding product geometry. Typical work-pieces: tractor cabinets, tanks, buckets, and frame structure parts.

With ALL TIME L - Positioner, workpiece can be adjusted in all possible positions. The completely rotatable L- arm allows the workpiece to rotate around their centre of gravity . This provides a productive working posture for welders, which can also be considered as ergonomical.

Turntable rotation and L-arm tilting are controlled by an inverter-controlled AC drives. Gears are integrated with self-locking mechanism for safe and smooth operation.

ALL TIME L - Positioner is integrated with a low voltage 24V remote control for all electrical operation and the display of digital rotation speed (rpm).

TEL: +852-2407-6414

EMAIL: info@allfitwelding.com



Standard components:

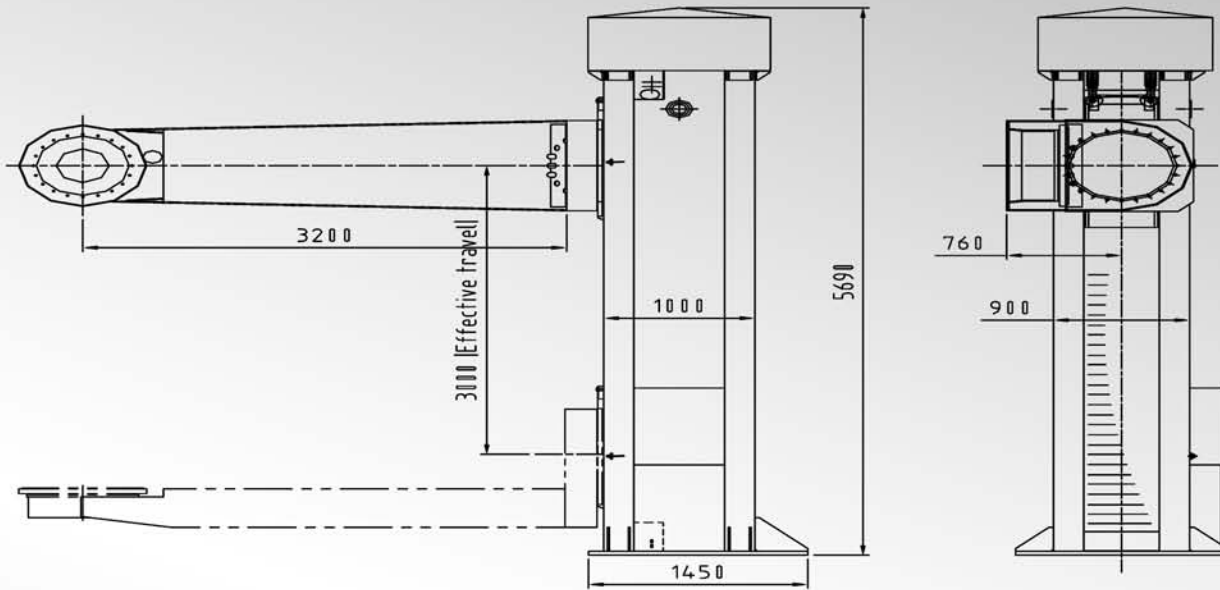

Technical Parameters:

Max. load (ton)	5
Rotational speed (rpm)	0.05~0.5
Tilting speed (rpm)	0.5
Lift Travel (mm)	3000
Rotational torch (N.m)	15000
Tilting torch (N.m)	15000
Max. center of gravity (mm)	300
Max. eccentricity (mm)	300
Range of tilting angle (°)	±180
Tilting mode	Power-driven

Note: 1 set of hydraulic jack up system: 1 hydraulic power unit + 5 hydraulic cylinders

Visit us at: www.alltimewelding.com

